

NPI-15 Series

Current Driven, Media Isolated High Pressure Sensors



Applications

- Process control systems
- Hydraulic systems and valves
- Automobiles and trucks
- Biomedical instruments
- Refrigeration and HVAC controls
- Appliances and consumer electronics
- Ship and marine systems
- Aircraft and avionic systems

Features

- Solid state, high reliability
- High sensitivity with 200 mV typical FSO with 1.0 mA
- 316L stainless steel, IsoSensor design
- Linearity 0.1% FSO typical
- Thermal accuracy 0.2% FSO typical
- Four standard ranges: 500 psi to 5,000 psi (34 bar to 345 bar) available
- Standard configurations include:
 - 1/2–20 UNF threaded male port with 1.0 in (25.40 mm) flange
 - 0.59 in (15 mm) diameter x 0.87 in (22 mm) long cylinder with o-ring seals
 - 1/4–18 NPT male port with 7/8 in flange
 - 1/8–27 NPT male port with 7/8 in flange
- Custom configurations and other pressure ranges available.

NPI-15 Series Specifications

Description

The NovaSensor NPI-15 Series incorporates state-of-the-art IsoSensor technology, which gives the OEM user the best in price and performance. They are designed to operate in hostile environments and yet give the outstanding sensitivity, linearity, and hysteresis of a silicon sensor. The piezoresistive sensor chip is housed in a fluid-filled cylindrical cavity and isolated from the measured media by a stainless steel diaphragm and body. As with all NovaSensor silicon sensors, the NPI-15 Series employs SenStable[®] processing technology, providing excellent stability.

The modular design allows for a variety of pressure port modules which are hermetically welded to the sensor header module. Standard types A, B, H, and J are shown to the right.

For compensation of temperature effects, a complete resistor network is supplied on a hybrid ceramic substrate. The IsoSensor design minimizes temperature errors to provide a maximum offset errors of 0.75% FSO over the 32°F to 158°F (0°C to 70°C) compensated range.

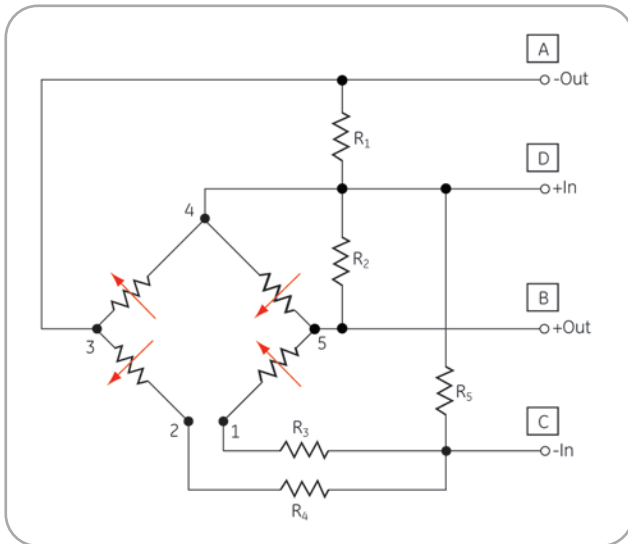

NPI-15 Series schematic diagram

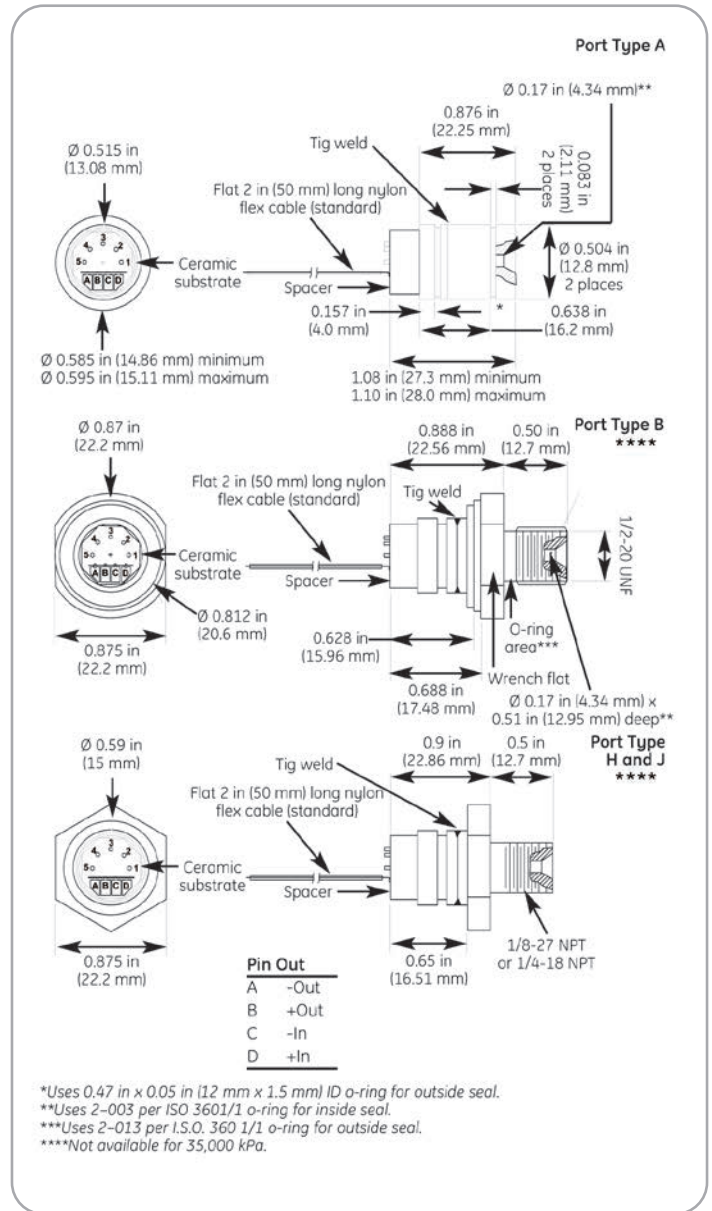

NPI-15 Series dimensions

NPI-15 Series Specifications

Parameter	Value	Units	Notes		
General					
Pressure Range	3500	kPa	507 psi		
	7000	kPa	1015 psi		
	35,000	kPa	5076 psi		
Maximum Pressure	2 x		rated pressure		
Electrical @ 77°F (25°C) unless otherwise stated					
Input Excitation	1.0	mA	1.5 mA maximum		
Insulation Resistance	100M	Ω	@ 50 VDC		
Input Impedance (min)	4,000	Ω	± 20%		
Output Impedance	5,000	Ω	± 20%		
Bridge Impedance	5,000	Ω	± 20%		
Environmental					
Temperature Range					
Operating ⁽⁹⁾	-40 to 257°F		(-40°C to 125°C)		
Compensated Range	32 to 158°F		(0°C to 70°C)		
Vibration	10	gRMS	20 to 2000Hz		
Shock	100	g	11 milliseconds		
Life (Dynamic Pressure Cycle)	10 x 10 ⁶	cycles	500/1000 psi 34.47/68.94 (bar)		
	1 x 10 ⁶	cycles	5000 psi (344.73 (bar)		
Mechanical ⁽¹⁾					
Weight	≈28	g	(28 g) NPI-15A-XXX		
	≈47	g	(47 g) NPI-15B-XXX		
Media Compatibility	All corrosive media compatible with 316 stainless steel				
Case and Diaphragm Material 316L stainless steel					
Recommended O-Ring Type A:	0.472 in (12 mm) ID x 0.059 in (1.5 mm) wall				
Type B:	2-013 per ISO 3601/1				
Performance Parameters 3,500, 7,000, & 35,000 kPa (Note 1, 8)					
Offset	mV	-2	1	2	
Full Scale Output	mV	170	200	230	2
Linearity	%FSO	-0.25	0.1	0.25	3
Hysteresis and Repeatability					
Repeatability	%FSO	-0.05	0.01	0.05	
Thermal Accuracy of Offset					
Thermal Accuracy of Offset	%FSO	-0.75	0.2	0.75	4
Thermal Accuracy of FSO					
Thermal Accuracy of FSO	%FSO	-0.75	-0.2	0.75	4
Thermal Hysteresis					
Thermal Hysteresis	%FSO	-0.2	0.1	0.2	5
Short-Term Stability of Offset					
Short-Term Stability of Offset	μV/V		5		6
Short-Term Stability of FSO					
Short-Term Stability of FSO	μV/V		5		6
Long-Term Stability of Offset					
Long-Term Stability of Offset	%FSO		0.1		7
Long-Term Stability of FSO					
Long-Term Stability of FSO	%FSO		0.1		7

Warranty

NovaSensor warrants its products against defects in material and workmanship for 12 months from the date of shipment. Products not subjected to misuse will be repaired or replaced. NovaSensor reserves the right to make changes without further notice to any products herein. NovaSensor makes no warranty, representation or guarantee regarding the suitability of its products for any particular application, nor does NovaSensor assume any liability arising out of the application or use of any product or circuit and specifically disclaims and all liability without limitation consequential or incidental damages. The foregoing warranties are exclusive and in lieu of all other warranties, whether written, oral, implied or statutory. No Implied statutory warranty of merchantability or fitness for particular purpose shall apply.

Ordering Information

NPI-15

Code Pressure Port Type

A	No port
B	1/2-20 UNF
H	1/4-18 NPT
J	1/8-27 NPT

Code Pressure Ranges (kilo Pascals (kPa); 3rd digit is number of zeros)

352	3500 kPa
702	7000 kPa
353	35,000 kPa (NPI-15A Only)

Code Compensation

A	Absolute
S	Sealed gauge
Code Voltage	
H	Constant Current Excitation

NPI-15 - - - - - Typical model number

- Performance with offset, thermal accuracy of offset and thermal accuracy of FSO compensation resistors.
- FSO with 1.0 mA input excitation.
- Linearity by best fit straight line.
- 32°F to 158°F (0°C to 70°C) with reference to 77°F (25°C).
- 32°F to 158°F (0°C to 70°C), by design.
- Normalized offset/ bridge voltage—100 hours, typical value, not tested in production.
- One year, typical value, not tested in production.
- All values measured at 77°F (25°C) and at 1.0 mA constant current, unless otherwise noted.
- Reduced performance outside compensation range, not tested in production.